

Fully Automated Frequency/Time Interval Counter Calibration

Application Note

Ask any electrical calibration laboratory what their main workload is and they'll probably list digital multimeters (DMMs), oscilloscopes and frequency/timer counters as the top three items. The first two items, DMMs and oscilloscopes, are calibrated quite efficiently by a variety of calibration products from Fluke. Frequency/timer counter calibration has not been as straightforward, until now. What is required to calibrate these devices depends on whether it is a routine calibration or a more comprehensive calibration following a repair.

A routine calibration of frequency/timer counters involves comparing it against a higher-level frequency reference standard. As the quantity of measurements is low, this is generally a manual process. Depending on the performance of the frequency counter, the standard may be a Cesium or Rubidium reference with specifications better than 1×10^{-12} per month. The frequency/counter parameters calibrated routinely in this manner are:

- Timebase oscillator
- Frequency and period measurement

Additional measurements, depending upon the calibration procedure used, might include:

- Short term timebase stability
- 24-hour aging of timebase

Calibration of a frequency/timer counter after repair often requires a more comprehensive calibration, as critical components may have been replaced or disturbed. The calibration may include the following additional parameters:

- Time delay multiple input channels
- Ratio performance
- Pulse width and rise time measurement
- Input channel sensitivity
- Trigger channel sensitivity and bandwidth
- Pulse amplitude
- Sine amplitude
- Impedance measurement

A Cesium or Rubidium reference standard will be adequate for short-term timebase stability and aging. The more comprehensive tests will require the addition of a time interval counter, a signal generator and an

impedance-measuring instrument to complete the calibration. Furthermore, as the number of measurements increase, so does the time it takes to calibrate a counter under test. Therefore, automated calibration software may be a consideration.

Three Fluke instruments are available to make up the references required to comprehensively calibrate frequency/time interval counters. The counter calibration system can be fully automated using Fluke's MET/CAL® Plus calibration software. In addition, MET/CAL calibration procedures are now available to calibrate all parameters for the most popular range of counters.



A basic counter calibration system to perform routine calibration includes a 910R GPS-Disciplined Rubidium Reference Standard, a PM 6681 Timer/Counter/Analyzer and MET/CAL Plus software.

A more comprehensive system requires the equipment above in addition to a source of signals that is traceable and covers the dynamic range of the counter workload. For this exercise, Fluke added the 9500B Oscilloscope Calibrator.

Why use an oscilloscope calibrator?

The Fluke 9500B Oscilloscope Calibrator can deliver a multitude of signals, including leveled sine to 6 GHz. The 9500B is basically a comprehensive signal source with traceability that was designed specifically to support oscilloscope calibration. However, the 9500B's comprehensive feature set, when accompanied by the Fluke 910R and PM 6681 counter, extends the workload of the 9500B to cover the most popular frequency/time interval counters, even after repair.

9500B features for use with frequency counter calibration:

- Additional channels to support multi-channel counters
- Ability to measure counter input impedance
- Adjustable pulse delay between output channels for counter inter-channel delay tests
- Adjustable and traceable leveled sine to 6 GHz for channel amplitude calibration, and trigger sensitivity
- External frequency reference lock input to improve timebase accuracy
- Switched 50 Ohm/1 MOhm termination

Counter calibration system

Figure 1 details a typical configuration of a counter calibration system using Fluke instruments. Interconnection between products is established using suitable BNC cables in series with a 50 Ohm terminator for impedance matching between the counter,

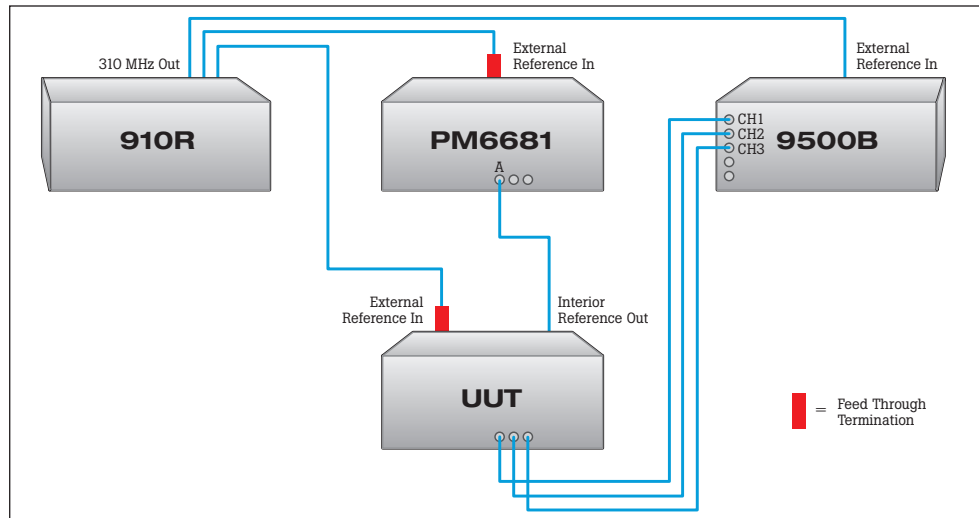

Figure 1. Typical configuration of a counter calibration system, using Fluke instruments.

frequency standard, and the unit under test. Note: the 9500B does not require external terminators as its 50 Ohm/1 MOhm termination is switched internally.

To help improve throughput, it is possible to connect the output of the 9500B to all input and trigger channels on the counter under test simultaneously. This will, however, depend on the number of 9500B Active Heads available.

System Accuracy

Specification based on a GPS locked 910R)

Timebase	1 x 10 ⁻¹²
Channel Delay	± 5 ps ch to ch
Sine Amplitude	5 %
Flatness to	3.2 GHz

Automation using MET/CAL® Plus calibration software

Function Select Codes (FSCs) for the referenced products described in Figure 1 are available within Fluke's MET/CAL Plus calibration software. Calibrating counters automatically also requires the appropriate UUT software calibration procedures. Example MET/CAL procedures are available from Fluke to cover the most popular counter/timers, including the PM 6680 and the Agilent 53131A.

Typically, counters supplied from the same manufacturer have similar test parameters; therefore a generic calibration

procedure could be considered for each counter series. A 29-page document entitled "Generic Frequency/Timer Counter Calibration Procedure" provides details about calibration system configuration, required stimulus and calibration test-points for both the PM 6680 and Agilent 53131A Frequency Counters. This document is available for download from the Fluke web site, www.fluke.com. Just go to the Calibrators product section and click on the "Application Notes" navigation button.

You can also find useful application notes by going through the product pages for Timer/Counters on the Fluke web site.

Fluke. Keeping your world up and running.®

Fluke Corporation
PO Box 9090, Everett, WA 98206 U.S.A.

Fluke Europe B.V.
PO Box 1186, 5602 BD Eindhoven, The Netherlands

For more information call:
In the U.S.A. (800) 443-5853 or Fax (425) 446-5116
In Europe/M-East/Africa +31 (0) 40 2675 200 or Fax +31 (0) 40 2675 222
In Canada (800)-36-FLUKE or Fax (905) 890-6866
From other countries +1 (425) 446-5500 or Fax +1 (425) 446-5116
Web access: <http://www.fluke.com>

©2002-2008 Fluke Corporation. MET/CAL is a registered trademark of Fluke Corporation. Specifications subject to change without notice. Printed in U.S.A. 10/2008 1677249 A-EN-N Rev B

Modification of this document is not permitted without written permission from Fluke Corporation.